

Installation Instructions

Surface Fixed

Djembes
Page 1 of 2

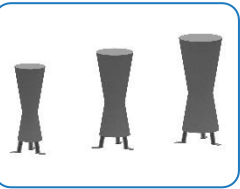

Instrument Components:

Djembes are pre-assembled

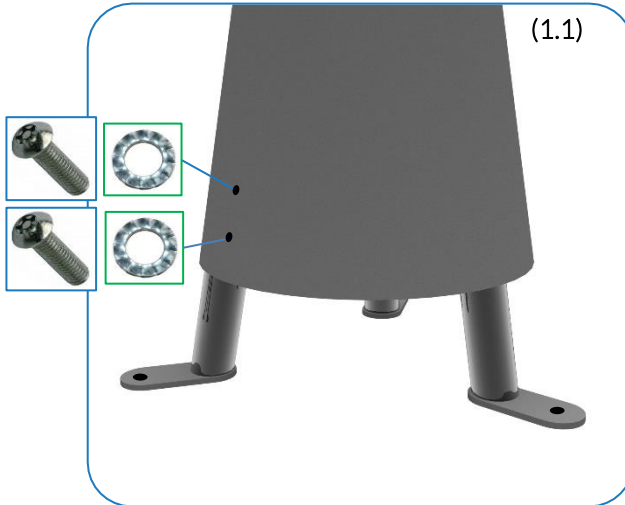
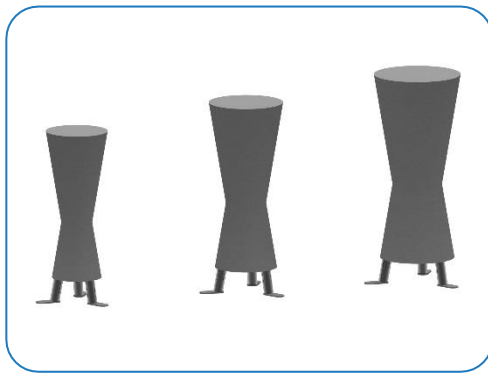

Weight of heaviest part 23kg (Large Djembe)

1. Assemble Ground Fixing Posts to base of sambas using M8x25mm security screws and lock washers. (1.1) (See Assembly Guide)

2. Arrange Djembes in desired location and mark holes to fix to desired surface.

3. Fix to Surface using recommended ground anchors (Ground Anchors are not supplied)

4. Make sure all fixings are covered and secure using cover caps provided

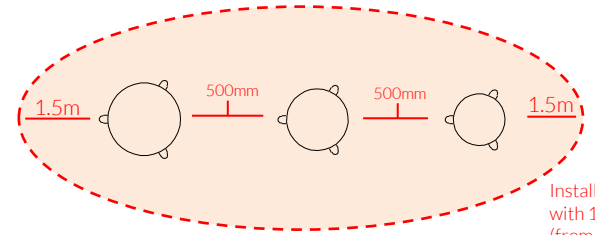

Install Instrument with 1.5m free space (from widest point) around it.

CAUTION: Drum surface can get hot in direct sunlight, if possible install in shaded areas.

Djembes will arrive on site in pre set heights.

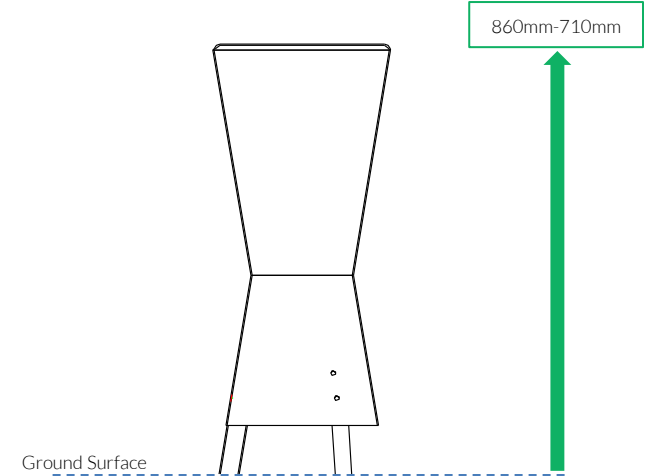

Surface Fix Components:

-  x18
-  x18
-  x9



Spares available from percussionplay.com or from your local distributor

48 Kg



Tools:
 x1
 TX 40 Driver Bit

Surface Fixed

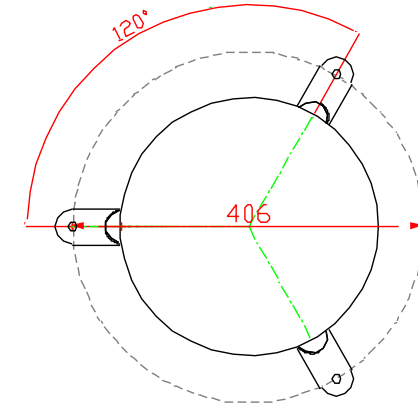
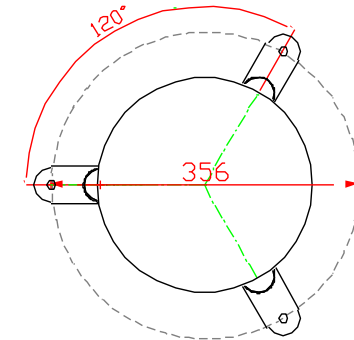
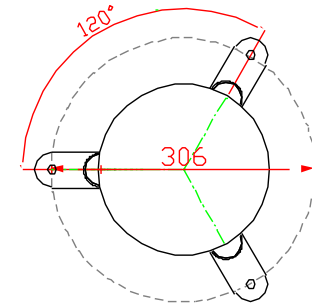
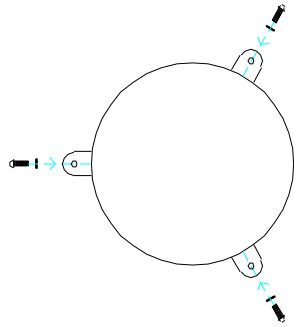
Djembes
Page 2 of 2



COMPONENTS LIST:

-  M8x25 Pin torx X18
-  M8 Lock washer X18
-  2 Part Cover Cap X9

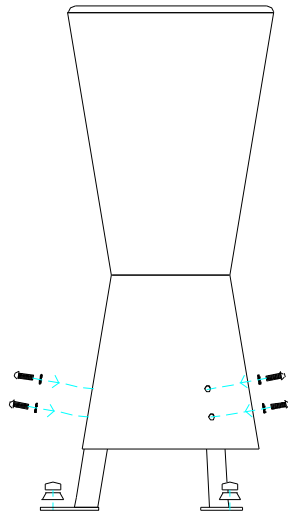

Instrument Components:

Djembes are pre-assembled



Surface Fix Components:



Spares available from percussionplay.com or from your local distributor

44 Kg